

---

## Water Quality Sampling Lesson Three: “Temperature”

### Academic Question:

1. How does water temperature affect aquatic ecosystems?

### Objectives:

- To understand the importance of temperature to an aquatic ecosystem.
- To perform temperature measurements.
- To evaluate seasonal change relationships between water temperature and stratification.
- To compare temperature changes for different aquatic systems.

**Key Terms:** stratification, photosynthesis, density, destratification

### Handouts:

[Temperature Test Procedures, Worksheet and Answers](#)

### Overview: Temperature

Although temperature may be one of the easiest measurements to perform, it is probably one of the most important variables to measure. It dramatically affects the rates of chemical and biochemical reactions within the water. All biological, physical, and chemical processes are influenced by temperature. Some of the most common of these are the solubility of compounds in water; rates of chemical reactions; density inversions and mixing; and movement of currents. Water temperature fluctuations depend on the type of water body. In shallower waters, such as streams and rivers, bays and bayous the temperature of water is much more susceptible to changes because its capacity to store heat over time is also relatively small. Lakes, however, are much more resistant to temperature change because the volume of water over a certain area is relatively large.

In deeper waters during the summer, the temperature of the surface and subsurface waters often differ, with water generally becoming colder as depth increases. This results in thermal **stratification** of deeper water, and can lead to density differences. Remember that cold water is heavier than warm water down to 4°C. In some lakes it is as if there are really two separate lakes - one lake with warm water that receives sunlight on top and underneath it another lake with cold water and little light. The water on top usually has enough oxygen for fish because it is in contact with air and it also receives sunlight for photosynthesis. The water near the bottom may lose much of its oxygen since there is no light to support plant production of oxygen and since it does not come in contact with the air. The temperature of the water, in the fall, as the warming radiation from the sun begins to diminish, cools on the surface, causing an increase in density and weight. Once the surface water becomes heavier than the warmer water underneath, it begins to sink, and destratification occurs. Wind may speed up the process as the mixing action brings nutrients from the bottom up into the surface water. The extra nutrients can sometimes cause an algae bloom that is indicated by the lake turning a darker greenish or brownish color. These bottom waters sometimes smell like a rotten egg due to the bacterial activity in an oxygen free environment.

### Process:

#### Activity 1: Introduction Activity – Water Sinking

1. Gather the following materials:
  - 3 test tubes
  - containers with red colored warm water – one per group
  - containers with blue colored ice water – one per group
  - containers with yellow colored room temperature water – one per group
2. Explain to the students their challenge is to layer the color one on top of the other in test tubes. They have 3 chances to make a test tube with separate colored layers. It is up to them, which order to add the colors.

3. Before allowing the student to begin the challenge, model how to use the straws to gently pick up a section of water by covering the straw top with a finger. Tilt the test tube, lower the straw inside, and uncover the straw top. Allow the students to practice this procedure for a limited time, during which they can pour out mixtures. During the challenge period, they must keep all layering attempts.
4. At the end of the challenge period, ask the students to list the order of water density by color, from most to least. (The densest water will be on the bottom of the test tube.) Ask student how the water density relates to water temperature?

### **Activity 2: Water Body Response to Heating**

1. Gather the following materials: large shallow plastic tray container, 3 milk jugs (one with the top cut off), tap water, sunny day or clamp lights.
2. Compare heating and cooling responses by water with different depths.
  - a. Allow the tap water to run out of the faucet until the water temperature reaches equilibrium. Measure 2 gallon tap water in the milk jugs
  - b. Pour one gallon into large shallow plastic container. Pour the second gallon into the milk jug with the top cut off.
  - c. Place each container outside in full sun, or under clamp lights.
  - d. Measure water temperature in both containers every 5 minutes.
  - e. Graph the change over time of both containers' water temperature.
3. Ask the students why equal amounts of water had different changes in water temperature. What water bodies found in nature might each container represent?

### **Activity 3: Practicing Testing Procedures for Air and Water Temperature in the Classroom**

Practice measuring air and water temperature, using Temperature Testing Procedures, in the classroom, using tap water.

### **Activity 4: Practicing Testing Procedures for Air and Water Temperature on a Water body**

1. Practice measuring air and water temperature in a natural water body.
2. Have students complete Worksheet 3.1 either in class or as homework.

### **Activity 5: Measuring Temperature in a Deep Water Body**

1. Mark a 20-meter line of rope in 1-meter increments. Tie a thermometer to the rope.
2. Locate a deep body of water. Measure water temperature at every 5-meter increments.
3. Graph the results on the graph below. The x and y axis are used in limnology, the study of inland waters.

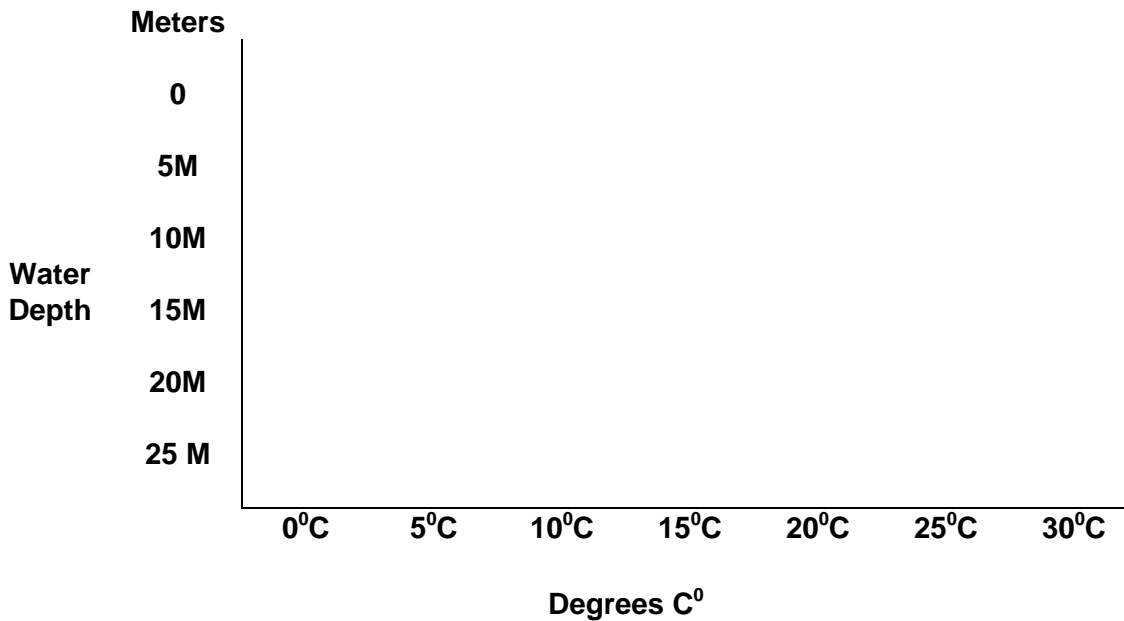
**Assessment/Evaluation:**

1. To evaluate the students' understanding of water density, have students discuss their findings in Activity 1 and discuss the positive and negative effects water temperature may have on an aquatic environment.
2. To assess the student's knowledge of a water body's response to heating, ask the students to explain why equal amounts of water in different containers produced different results in water temperature. Also, have students discuss what type of water body might these containers represent.
3. The student's Worksheet 3.1 may be used as an overall assessment of the students' knowledge of how temperature may affect aquatic ecosystems.

**Resources:**

Texas Watch Water Monitoring Manual

**Helpful Hint to Repair a Separated Thermometer:**

The following are methods for reuniting a separated alcohol column in a thermometer:

Cooling Method—With the thermometer in an upright position, cool the *bulb only* in a solution of shaved ice and salt so that the alcohol column retreats slowly into the bulb. Remove and swing thermometer in a short arc forcing the entrapped gas to the top of the alcohol. Allow the bulb to warm slowly in the air.

Heating Method—Heat the thermometer bulb in warm water sufficient to allow the alcohol to rise slowly, until the separation and a portion of the main column enter the chamber. Tap the thermometer in palm of hand or on a padded surface reuniting the column. Allow to cool slowly.

**Time Frame:** Two 45-50 minutes

**Grade Level:** 8<sup>th</sup> – 12<sup>th</sup> Grade

## Temperature Test Procedures

### Measuring Temperature

Temperatures are reported in degrees Celsius (C). The following table provides Fahrenheit conversions to degrees Celsius.

**Fahrenheit Conversions to Degrees Celsius**

°C	°F		°C	°F		°C	°F
0	32		13	55.4		26	78.8
1	33.8		14	57.2		27	80.6
2	35.6		15	59		28	82.4
3	37.4		16	60.8		29	84.3
4	39.2		17	62.6		30	86
5	41		18	64.4		31	87.8
6	42.8		19	66.2		32	89.6
7	44.6		20	68		33	91.4
8	46.4		21	69.8		34	93.2
9	48.2		22	71.6		35	95
10	50		23	73.4		36	96.8
11	51.8		24	75.2		37	98.6
12	53.6		25	77		38	100.4

### AIR TEMPERATURE:

- Step 1:** Locate a place near your site to test the air temperature.  
**Step 2:** Hang the thermometer on the dock, pier, or a tree out of direct sun and wind.  
**Step 3:** Wait 2-3 minutes to allow the thermometer to equilibrate.  
**Step 4:** Record the value to the nearest one ½ degree C on your paper.

**When reading the thermometer, always hold the thermometer on the end that is opposite the thermometer bulb.**

**Remember to measure air temperature before you measure water temperature. A wet thermometer will not accurately measure air temperature.**

### WATER TEMPERATURE:

- Step 1:** When you have collected the water sample in the bucket or beaker, remove the sample container from direct sunlight and wind.  
**Step 2:** Do not hold the bucket or beaker in your hands because your hands might begin to warm the water.  
**Step 3:** Put the thermometer in the bucket for one and a half minutes and record the value to the nearest ½ degree C.  
**Step 4:** Read the thermometer while the bulb and lower part of the thermometer are underwater.  
**Step 5:** Never take the thermometer out of the water to read the temperature.  
**Step 6:** If your site is appropriate, you may place the thermometer directly in the stream or lake.

## Temperature Worksheet

1. Why is temperature one of the most important variables when measuring water quality?

---



---

2. What type of water body is more susceptible to temperature change?

---



---

3. During the fall season, on some lakes, a lake may become dark green to brownish and color and have a bad odor – explain why this happens.

---



---



---

4. When testing in the field, why it is important not to measure the air temperature before you measure the water temperature?

---



---



---

5. Indicate fall, winter, or summer season for each of the lake drawings:

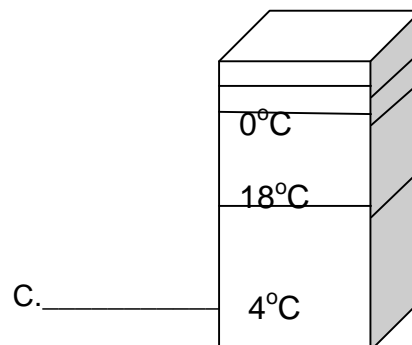
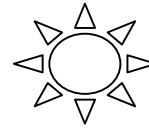
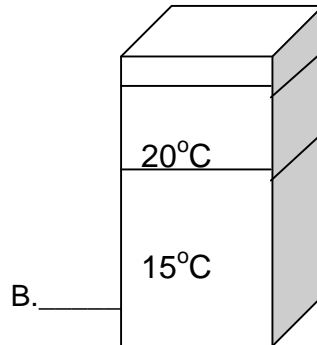
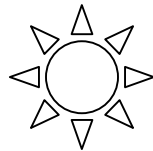
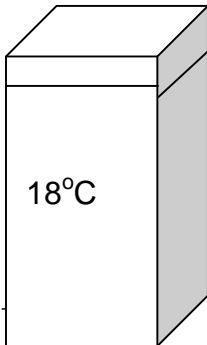
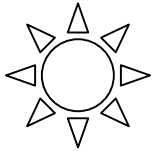

6. When water becomes stratified, or forms separate layers with different temperatures, oxygen no longer reaches the bottom layer. How would that affect aquatic life?

---



---



---

7. When temperatures cool in the fall and the surface water becomes heavier, the lake waters mix. What important deposits on the bottom of the lake become available?

---



---



---

## Temperature Worksheet--Answers

1. Why is temperature one of the most important variables when measuring water quality? **All biological, physical, and chemical processes are influenced by water. It dramatically effects the rates of chemical and biochemical reactions within water.**
2. What type of water body is more susceptible to temperature change? **Shallow streams and rivers, bay and bayous are more susceptible to temperature change because of their capacity to store heat over time.**
3. During the fall season, on some lakes, a lake may become dark green to brownish and color and have a bad odor – explain why this happens. **The water temperature on the surface and the water temperature on the subsurface often differ, with the water generally becoming colder as depth increases. This results in thermal stratification of deeper water, and can lead to density differences. As the surface water begins to cool in fall, it increases in density and becomes heavier. Once the surface water becomes nearly as heavy as the water toward the bottom, it begins to sink and destratification occurs. These bottom waters sometimes smell bad and have at times a dark green or brownish color.**
4. When out testing in the field, explain why it is important not to measure the air temperature before you measure the water temperature? **A wet bulb on the thermometer will not accurately measure the correct air temperature.**
5. Indicate fall, winter, or summer season for each of the lake drawings:

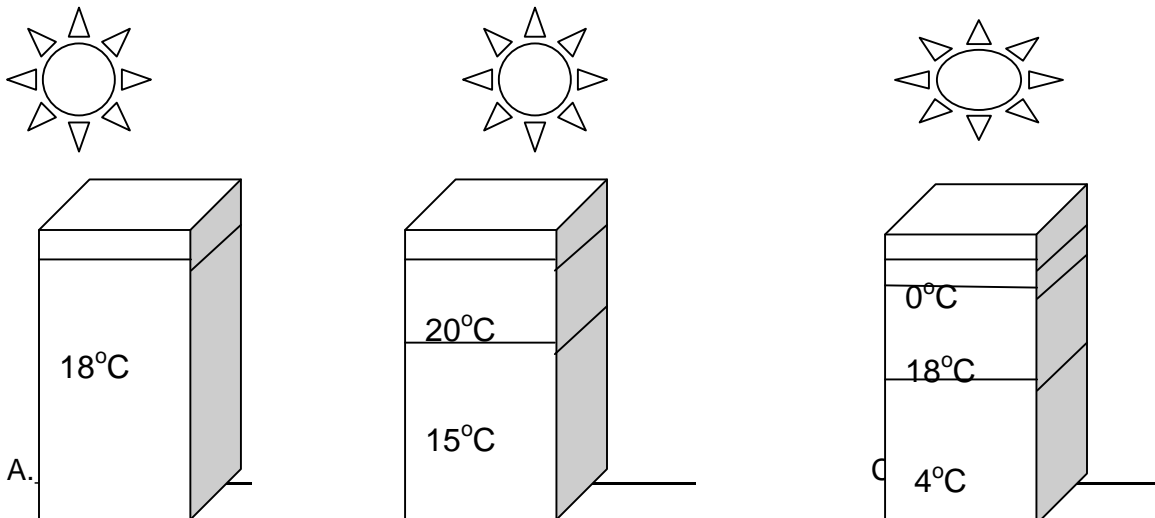

**Lakes in Texas have stratified waters in winter and summer as surface waters warm up or cool down and unstratified waters in the fall, as cooled water drops and causes mixing.**

6. When water becomes stratified, or forms separate layers with different temperatures, oxygen no longer reaches the bottom layer. How would that effect aquatic life? **Organisms slow down and use less oxygen, and move away from the bottom or die.**
7. When temperatures cool in the fall and the surface water becomes heavier, the lake waters mix. What important deposits on the bottom of the lake become available? **Nutrients become available.**

This curriculum was developed with education grant funds through the Texas Education Agency for nonprofit educational uses and cannot be sold or used for profit in any way. Special thanks to Texas Watch, the Environmental Protection Agency and the Texas Natural Resource Conservation Commission for the use of this curriculum.